

WD-01047602

Juego biosaludable "LOS PEDALES".

Revision: 01 - 27/01/2017

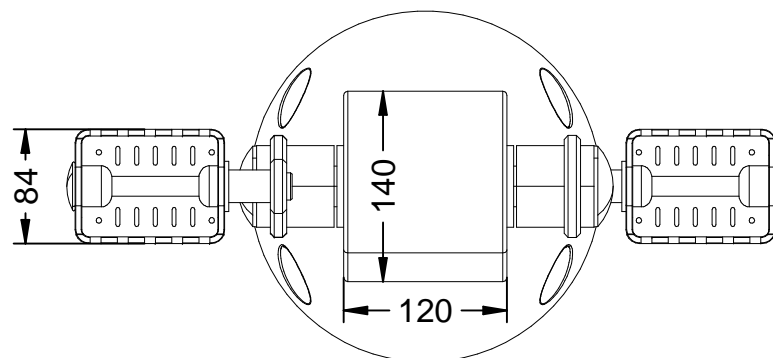
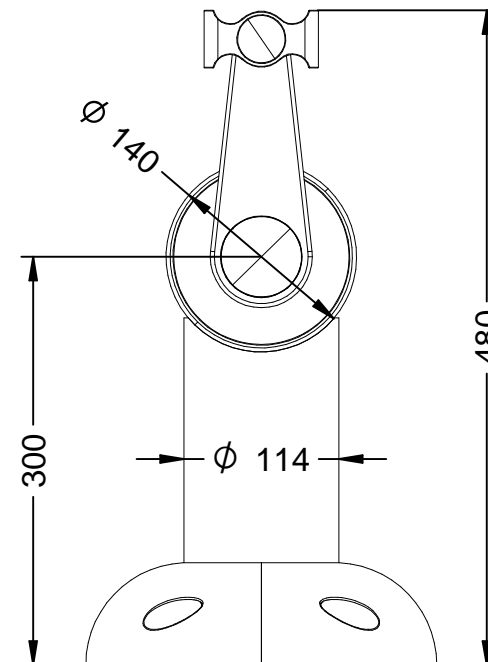
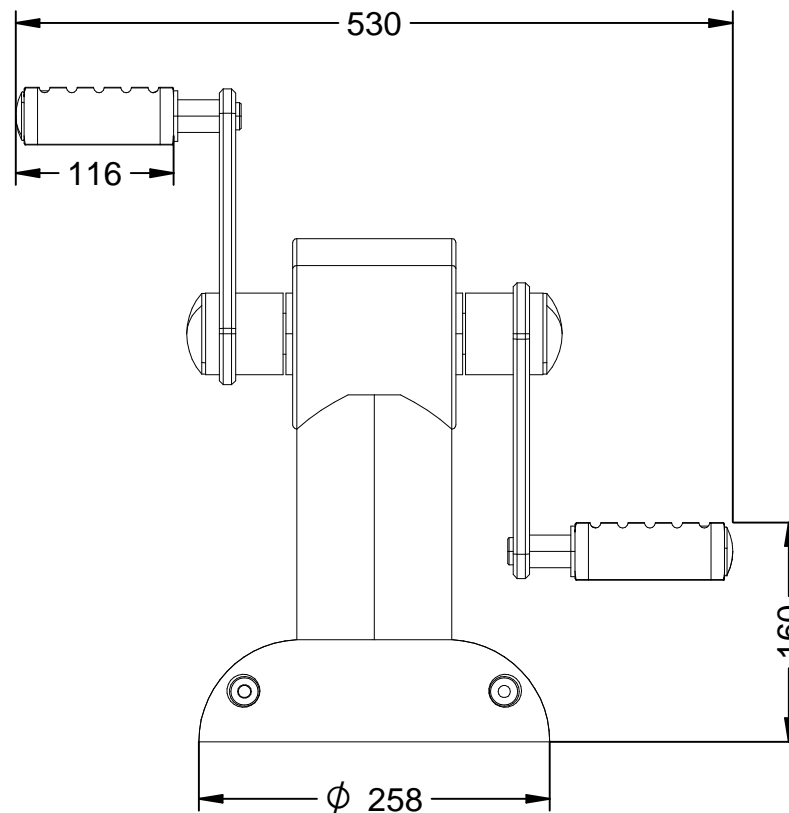

WD-01047602

Juego biosaludable "LOS PEDALES".

Revision: 01 - 27/01/2017



-ES- 

Descripción: Juego Biosaludable "Los Pedales".

Características: Fortalece las funciones cardíaca y pulmonar desarrollando la flexibilidad y coordinación de os miembros inferiores.

Material: Tubo de acero galvanizado.

Medidas: 530 x 140 x 480 mm.

-CA- 

Descripció: Joc Biosaludable "Los Pedales".

Característiques: Enforteix les funcions cardíaca i pulmonar desenvolupant la flexibilitat i coordinació dels membres inferiors.

Material: Tub d'acer galvanitzat.

Mesures: 530 x 140 x 480 mm.

-EN- 

Description: Biosaludable "Los Pedales".

Characteristics: Strengthens the cardiac and lung functions developing flexibility and coordination of the lower limbs.

Material: Galvanized steel tube.

Measures: 530 x 140 x 480 mm.

-FR- 

Description: Jeu Biosaludable "Los Pedales".

Caractéristiques: Renforce les fonctions cardiaques et pulmonaires le développement la souplesse et la coordination des membres inférieures.

Matériel: Tube en acier galvanisé.

Mesures: 530 x 140 x 480 mm.

-PT- 

Descrição: Jogo Biosaludável "Los Pedales".

Características: Fortalece as funções do coração e do pulmão desenvolvendo a flexibilidade e coordenação dos membros inferiores.

Material: Tubo de aço galvanizado.

Medidas: 530 x 140 x 480 mm.